

# **Purposes of Session on Patient Safety and Pharmacy**

**Review Plans for Bold New HRSA Initiative**

**Provide Data on Growth of Pharmacy Services**

**Gain PCA & CHC Perspective, Ideas and  
Potential Involvement & Leadership in this  
Work**

A red spiral graphic that starts at the bottom left and moves upwards and to the right, crossing a vertical line.

**Getting on an Upward Spiral**

**In Action to Improve Healthcare Quality**

# Some Key Questions

- *How safe are HRSA-funded programs and their partnering organizations?*
- *What can we do to increase the quality and safety of these programs, especially in growth areas like medication management and pharmacy services?*
- *What are the emerging plans for making improvements?*
- *What would be potential benefits to PCAs, CHCs and others for becoming involved in this work?*



Getting on an Upward Spiral

In Action to Improve Healthcare Quality

# Patient Safety & Pharmacy Initiative Goals

- **Improve Patient Safety**
  - **Increased Compliance w/ NQF Guidelines**
  - **Fewer Errors, Fewer Injuries, Less Harm**
  - **Possible Reductions in Size & Number of Tort Claims**
- **Increase High Quality, Cost-Effective Pharmacy Services**
- **Improve Health Outcomes**



Getting on an Upward Spiral

In Action to Improve Healthcare Quality



# Patient Safety & Clinical Pharmacy Initiative Plan

- Work with internal and external stakeholders
- Identify safety-net “best practice” models of patient safety/clinical pharmacy services from among HRSA grantees & their partners
- Use collaborative model to get best practices used by other safety-net providers



Getting on an Upward Spiral

In Action to Improve Healthcare Quality

# 2 Phases of Work

**Phase 1: Study & Capability Development**  
**October, 2007 to April, 2008**

**Phase 2: Implementation, Action & Results**  
**May, 2008 to October, 2009**



Getting on an Upward Spiral

In Action to Improve Healthcare Quality

# Timeline & Milestones

- **30 Site Visits by March**
- **Clustered in 7 Areas**
  - **1<sup>st</sup> Area & 5 Sites Last Week in AZ**
- **Expert Panel in April**
- **Team Application & Enrollment in May & June**
- **First Learning Session in August**
- **Continued Work Thru 11/2009**



Getting on an Upward Spiral

In Action to Improve Healthcare Quality

# Our Partners...and More

- **Federal Partners: HRSA Bureaus & Offices, AHRQ, CMS, CDC**
- **CHCs, FQHCs, DSH Hospitals, Rural Health Clinics**
- **State Organizations: PCAs, State Medicaid Offices, PCOs, SORHs, State Hospital Assns, Health Foundations, more**
- **Safety Net Organizations: NACHC, PCAs, NRHA, NAPH, 340B Coalition, SNHPA**
- **Pharmacy Organizations: APhA, AACP, ASHP, ACCP, AMCP, NACDS, PQA, ISMP, PSSC, Appexus/340B Prime Vendor**
- **Quality Organizations: NQF, IHI, JCAHO**
- **Poison Control Centers**
- **Others Who Want to Be Involved**



Getting on an Upward Spiral

In Action to Improve Healthcare Quality

# Background: Institute of Medicine on Patient Safety

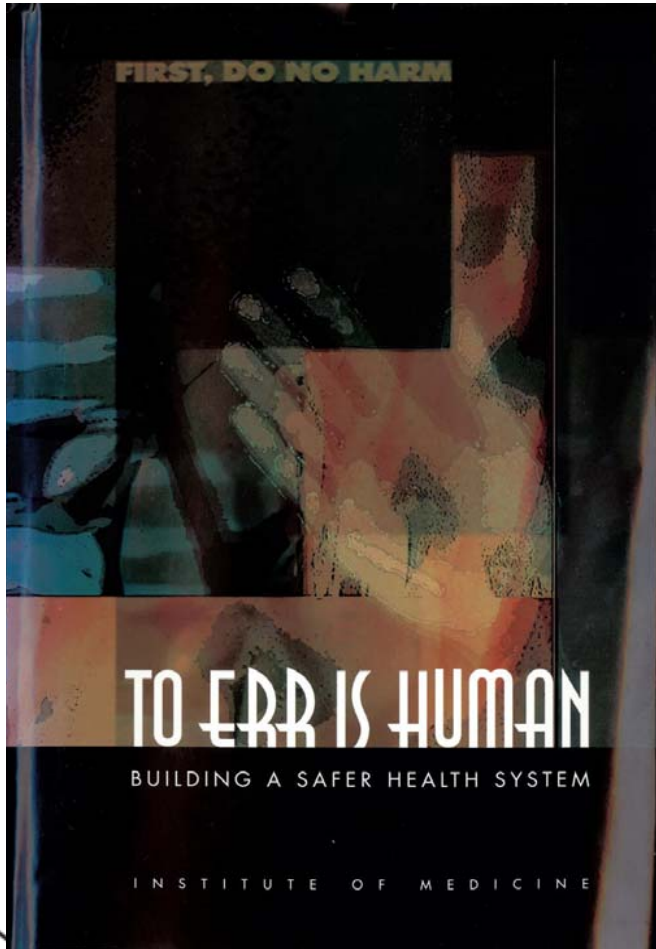

- Medication Errors are Most Common
- Injure 1.5 Million People Annually
- Cost Billions Annually

*“...for every dollar spent on ambulatory medications, another dollar is spent to treat new health problems caused by the medication.”*

 Getting on an Upward Spiral

In Action to Improve Healthcare Quality





# Two Truths About the Patient Safety & Clinical Pharmacy Initiative

- **Pharmacy services in HRSA programs & safety-net partners are growing rapidly**
- **HRSA & Administrator Duke desires these programs to be the best and safest in the United States**



Getting on an Upward Spiral

In Action to Improve Healthcare Quality



### Growth of Section 340B Covered Entity Sites

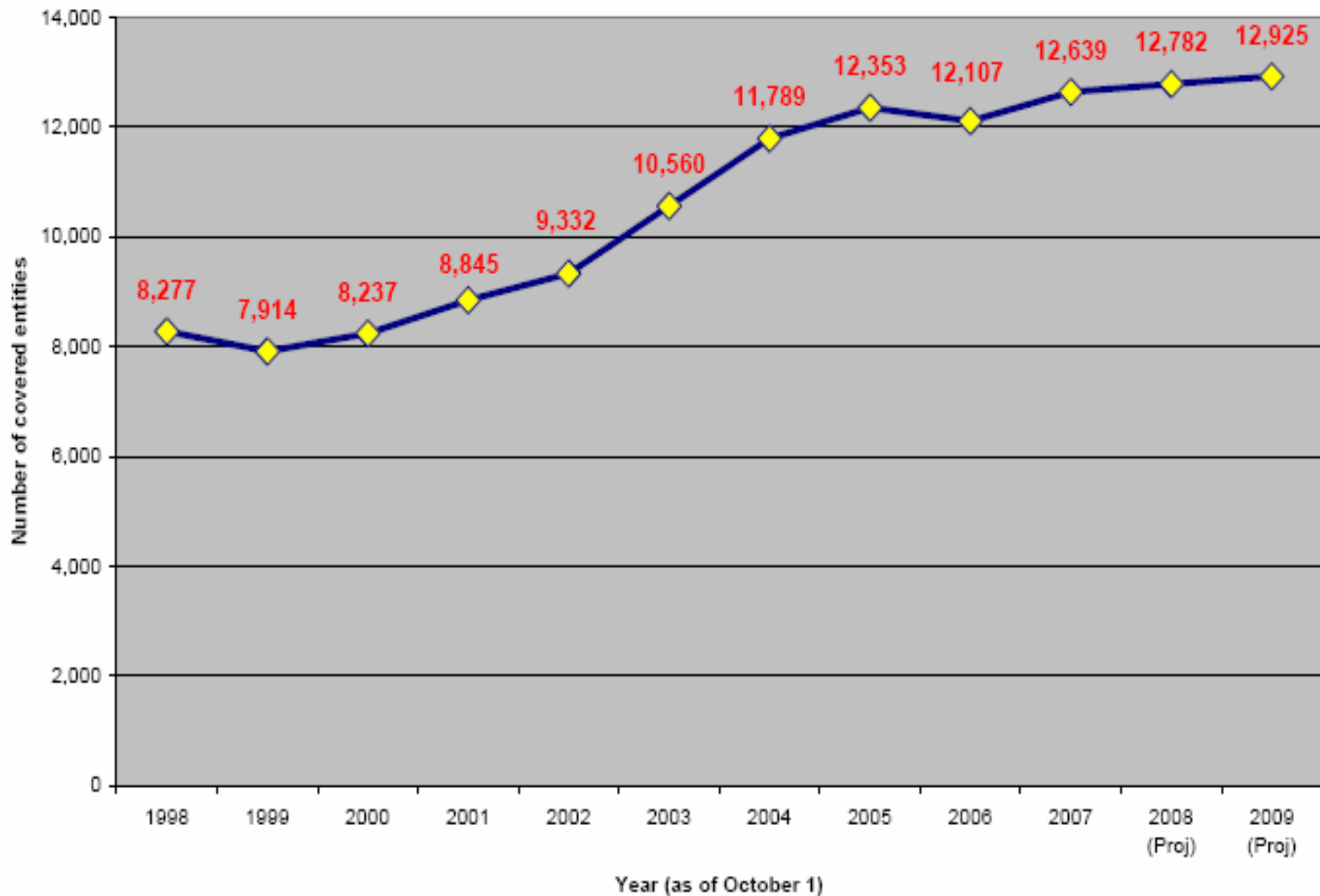

Growth of Section 340B Covered Entity Sites by Agency

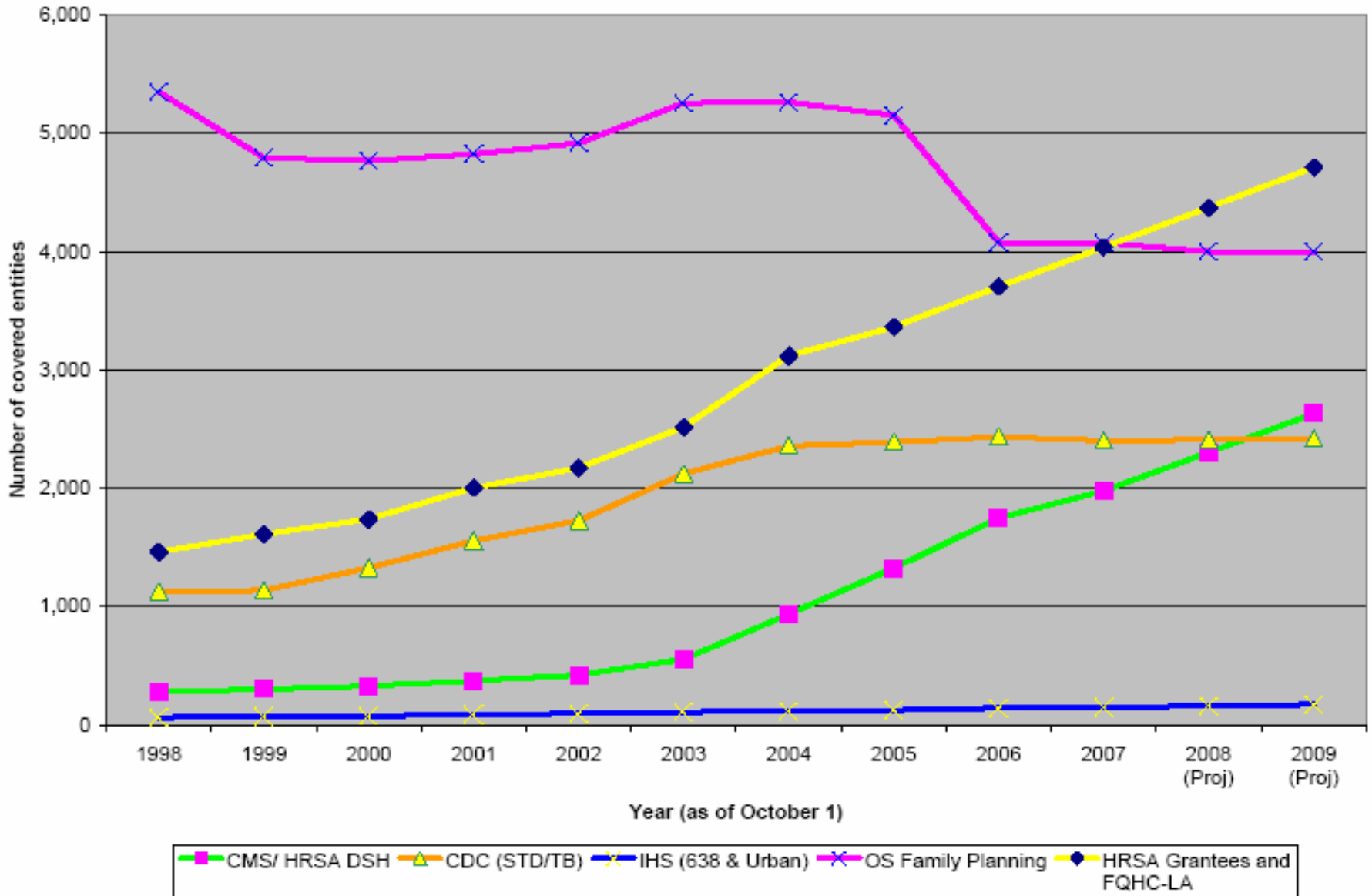

# Growth in 340B Contract Pharmacy Arrangements

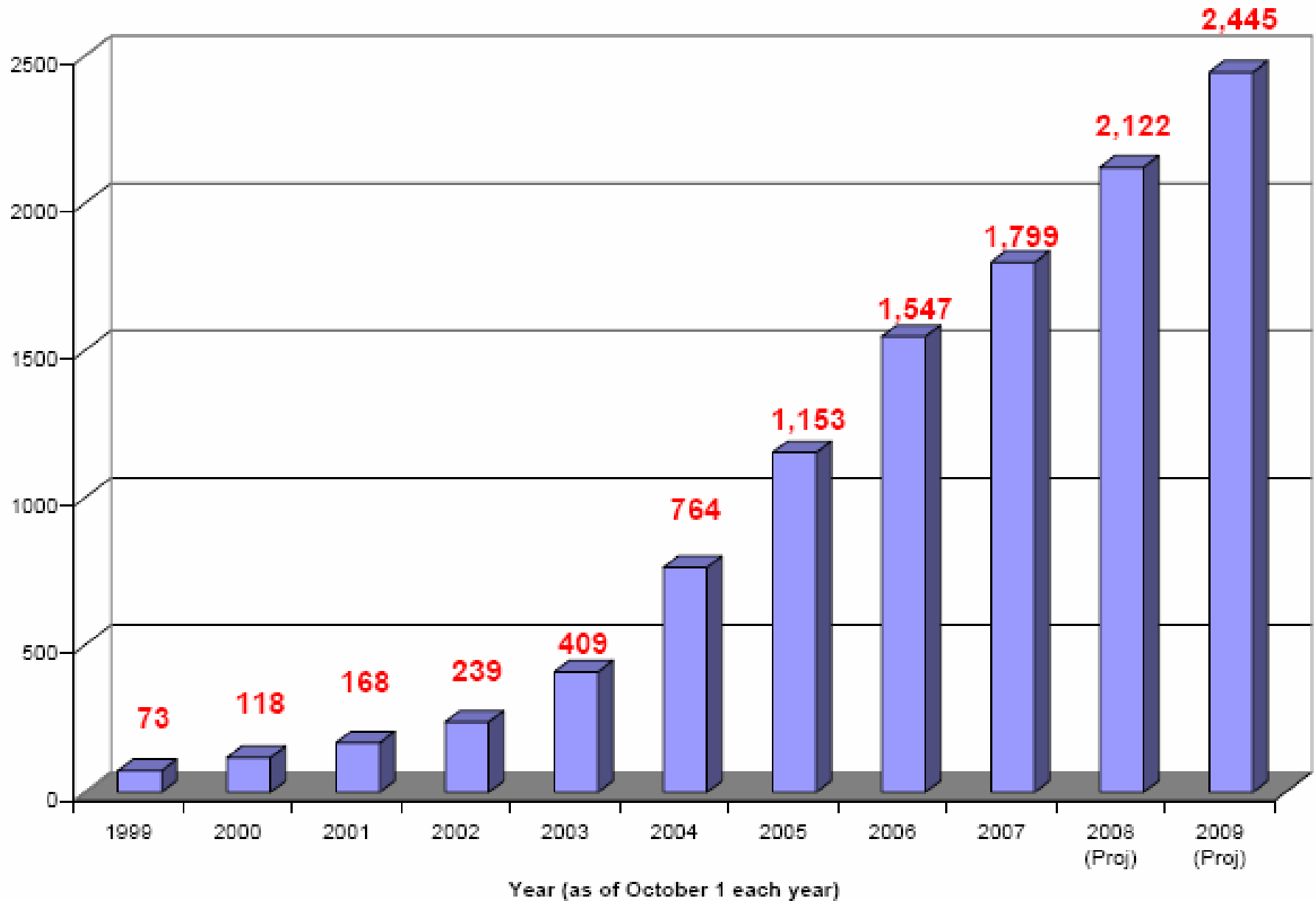

Getting on an Upward Spiral

In Action to Improve Healthcare Quality



# FY 2007 & 2008 Senate Appropriations Committee Reports Encourage HRSA Pharmacy Collaborative Implementation:

*“The Committee further encourages HRSA to establish a pharmacy collaborative to identify and implement best practices, which may improve patient care by establishing the pharmacist as an integral part of a patient-centered, interprofessional health care team.”*



Getting on an Upward Spiral

In Action to Improve Healthcare Quality

# Two Questions for Discussion & Response

*What are your insights and reactions to the Patient Safety and Pharmacy initiative?*

*What might be benefits to PCAs and Health Centers of participating in this quality initiative?*



Getting on an Upward Spiral

In Action to Improve Healthcare Quality

# Generating Synergy on HRSA's Quality Agenda

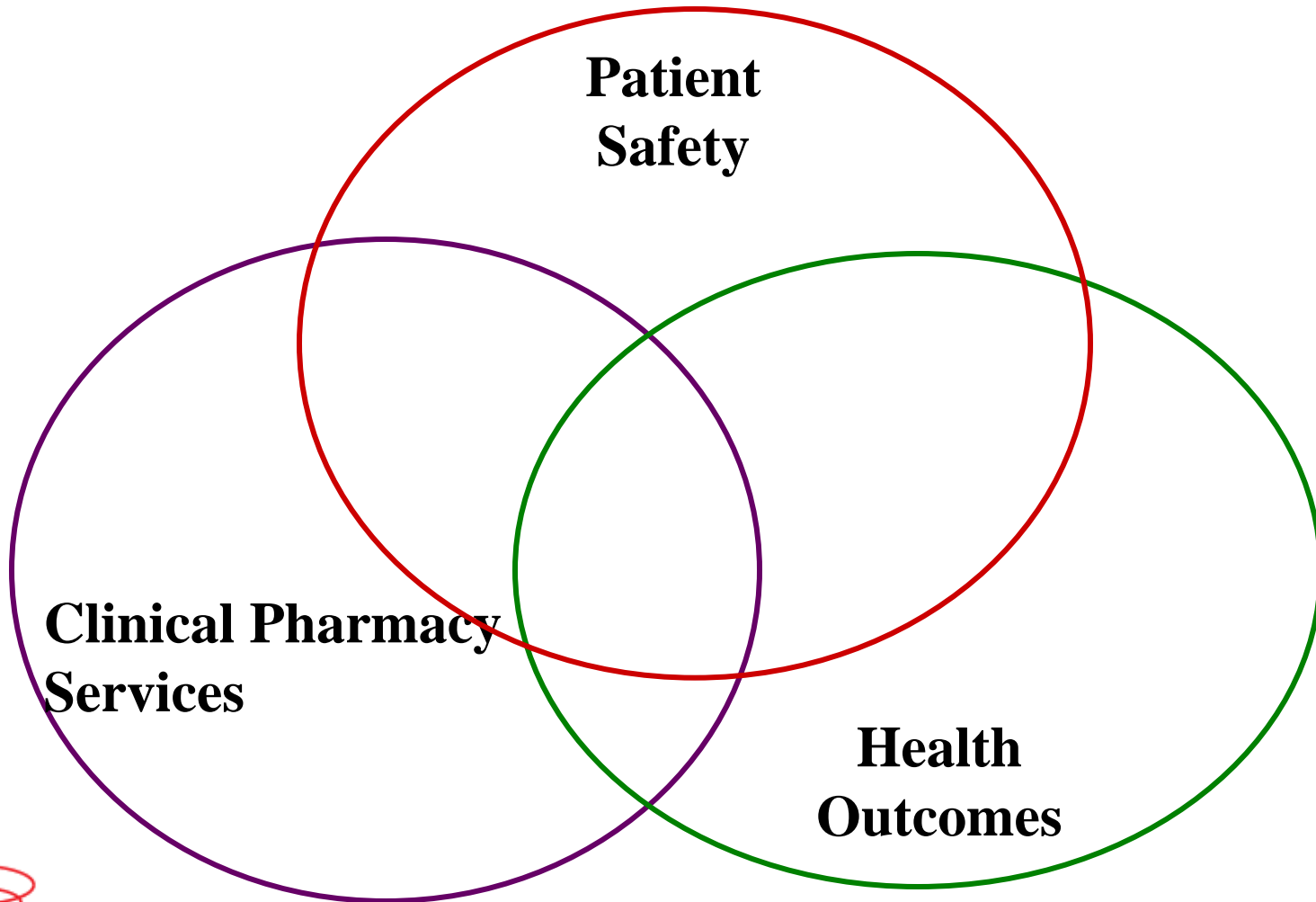

Getting on an Upward Spiral

In Action to Improve Healthcare Quality



# Patient Safety x Pharmacy Services x Health Outcomes on Core Measures =



*Patient  
Centered  
Quality*



Getting on an Upward Spiral

In Action to Improve Healthcare Quality



# Patient Safety & Pharmacy Initiative – Study Phase

- **Identify and learn from HRSA grantees and healthcare partner organizations with results and successes**
  - Pharmacy
  - Patient Safety & Health Literacy
  - Health Outcomes
- **Document best practices of high performers in a Change Package**
- **Enroll high performers as faculty leaders in national improvement initiative**
- **Conduct HRSA Patient Safety & Health Literacy Inventory to identify already existing tools and resources**

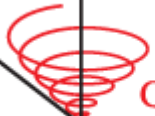

Getting on an Upward Spiral

In Action to Improve Healthcare Quality

# National Quality Forum

## Harmonized Practices on Safety

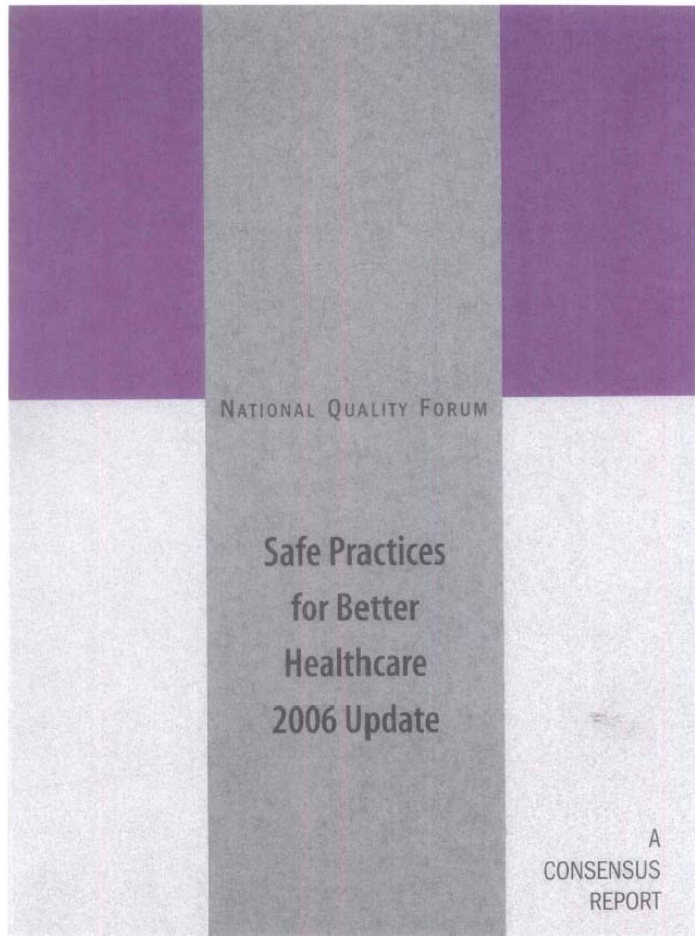

- *Culture of Safety and Leadership*
- *Informed Consent*
- *Service Delivery*
- *Information Transfer and Clear Communication*
- *Medication Management*
- *Healthcare Associated Infections*
- *Condition/Site Specific Practices*

# We Already Have High Performers

- *What can we learn from them?*
- *Who else is already succeeding in this work?*

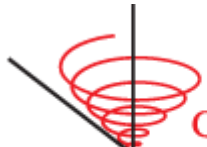

Getting on an Upward Spiral

In Action to Improve Healthcare Quality

Sunday, September 30, 2007

# *Program gives pharmacists more clout in patient care*



*During more than two years, patients with diabetes referred to the pharmacist program at the [JWCH Medical Clinic at the Weingart Center](#) on Los Angeles' Skid Row showed an average drop in blood sugar levels of 3.7 percentage points, a significant drop.*

**Pharmacist Steven Chen with Diabetic Patient George McLucas**



Sunday, September 30, 2007

# *Program gives pharmacists more clout in patient care*

*At another community clinic — The El Rio Community Health Center in Tucson — a group of diabetes patients referred to its pharmacist-overseen program had lower blood sugar levels after six months than counterparts getting standard care.*

*Results like those could help lead to more such efforts, as both government health programs and private insurers look for ways to control some of the most costly diseases. Preventing the complications of diabetes, including blindness, limb amputations, heart disease and stroke, could not only save lives, but also reduce hospitalization and other medical costs...*

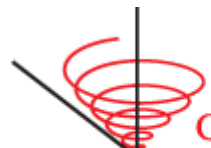

Getting on an Upward Spiral

In Action to Improve Healthcare Quality

# List of Some Potential High Performing Organizations

- **Kaiser Permanente in CO**
- **Baylor & Parkland in Dallas**
- **VA System**
- **El Rio Health Center in Tucson**
- **Westside Health Center in Minneapolis**
- **John Albrecht Medical Center in Pontiac, IL**
- **Harris County Hospital District, Houston, TX**
- **Paynesville Area Health Care System, MN**
- **Missouri Medicaid**
- **USC & Associated Health Centers, CA**
- **DFD Russell Medical Center, ME**
- **...more**



Getting on an Upward Spiral

In Action to Improve Healthcare Quality

# Patient Safety & Pharmacy Initiative – Implementation Phase

- **Establish quantitative aims to guide improvement**
- **Enroll HRSA grantees and their partners in national peer-to-peer technical assistance & collaboration initiative**
- **Help these teams generate rapid improvements**

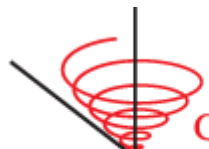

Getting on an Upward Spiral

In Action to Improve Healthcare Quality

# **We Are Using & Adapting Proven Models & Methods**

**BPHC Health Disparities Collaboratives**

**HSB Organ Donation & Transplantation  
Breakthrough Collaboratives**



Getting on an Upward Spiral

In Action to Improve Healthcare Quality



# Our Collaborative Process

---

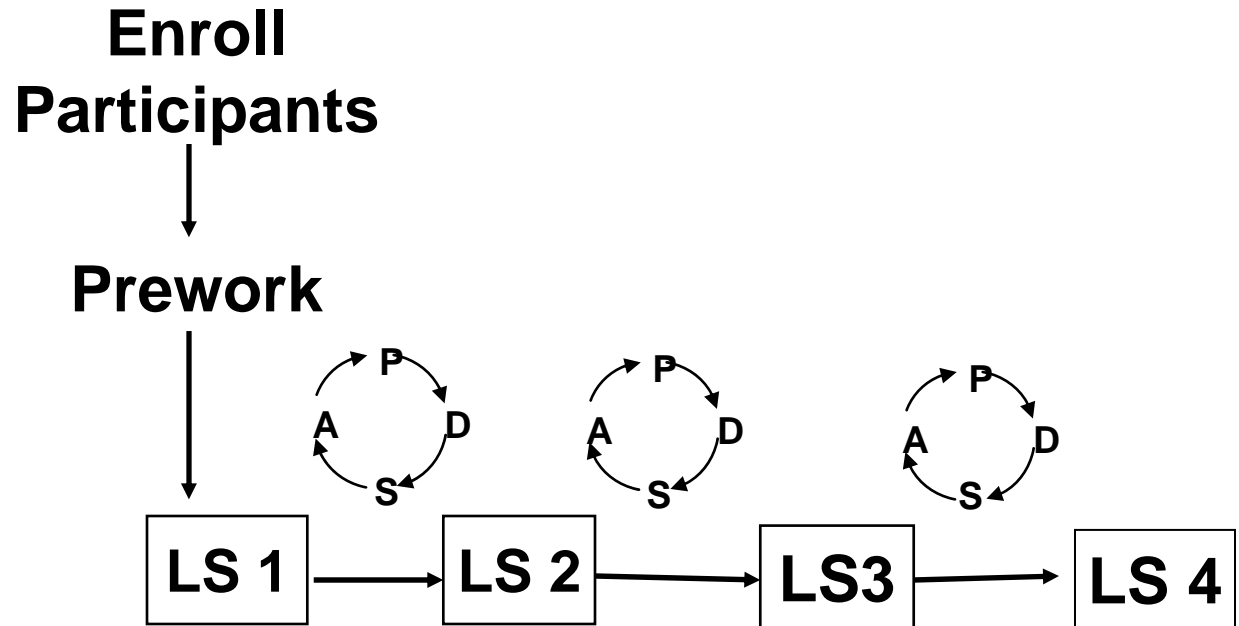

***Series of action learning events  
generating commitments to PDSA  
actions back home.***

# Our Collaborative Process

---

**Enroll  
Participants**



**Prework**

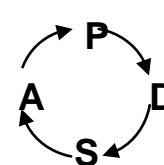
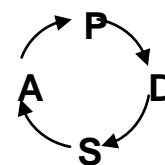
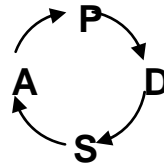

**LS 1**



**LS 2**



**LS3**



**LS 4**

## **Team Support**

- ListServe
- Site Visits & Filming
- Conference Calls
- Rapid Sharing
- Team Reporting
- Website
- Leadership Coordinating Council

# Our Collaborative Process

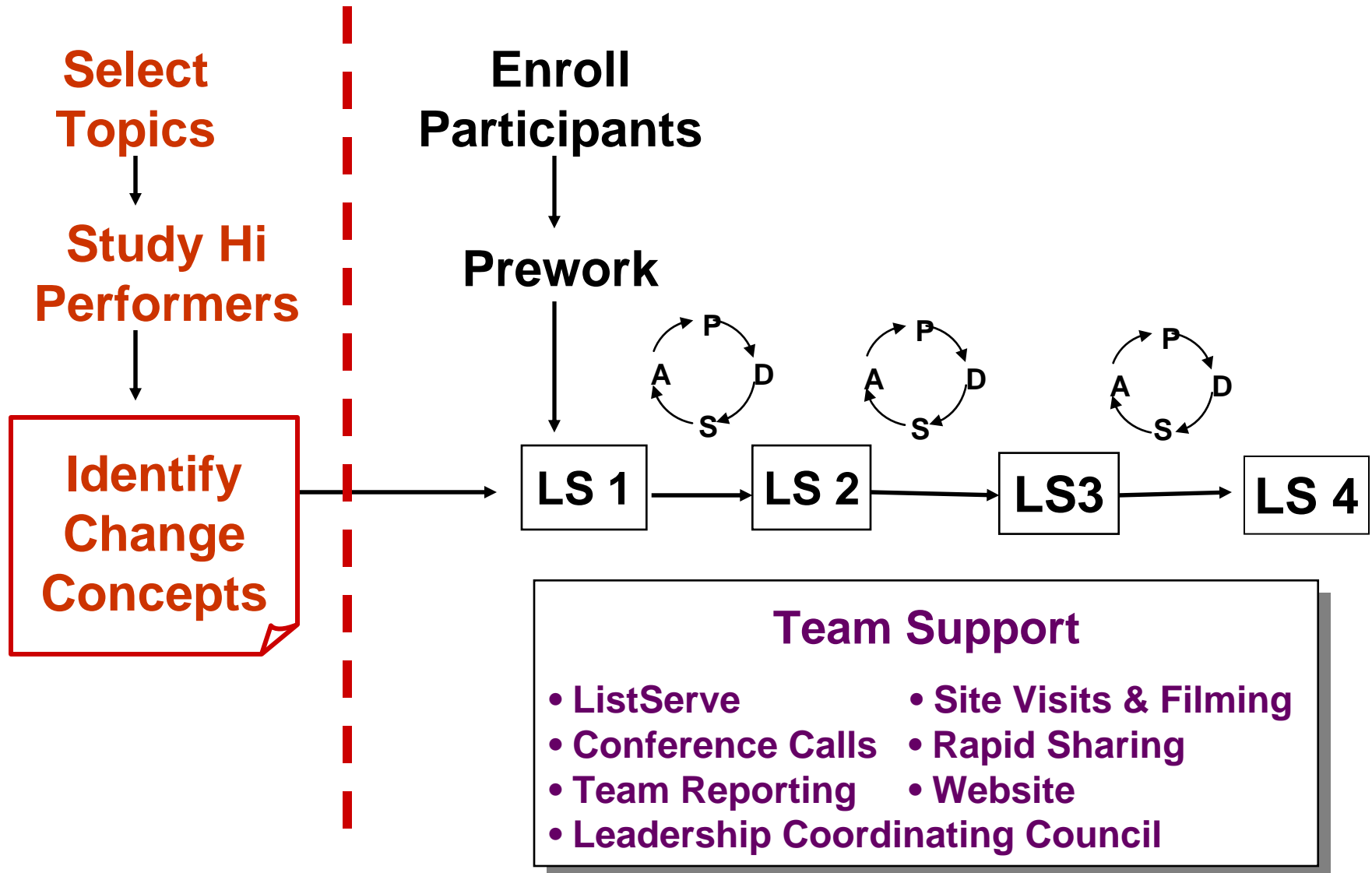

# *What are some of the ways PCAs might be able to help lead on this exciting work?*

- Help identify high performers in the 3 key areas of work.
- Help organize and supporting cross-cutting teams to participate in the Implementation Phase of this work.
- Join with HRSA & other State Partners in hosting Learning Sessions & other events.
- Help teams succeed in generating results.
- Recognize high performers and help spread their success.
- What else?



Getting on an Upward Spiral

In Action to Improve Healthcare Quality

# Principles & Tone

- All Teach; All Learn
- Inclusive
- Aspirational
- Voluntary
- Ambitious
- Doing More of What Works
- Involving Patients
- Improving Quality of Care



Getting on an Upward Spiral

In Action to Improve Healthcare Quality

# Questions for Discussion & Response

*What excites you about this initiative?*

*What are your ideas for how you might want to contribute to or participate in this initiative?*

*What would you suggest adding to or improving about the plan?*



Getting on an Upward Spiral

In Action to Improve Healthcare Quality

## Presentation Link

<http://www.healthdisparities.net/hdc/hdcsearch/isysquery/d2ff8917-d81d-4e51-9790-e0e3f9f67593/14/doc/>

## Recording Link:

<http://www.healthdisparities.net/hdc/hdcsearch/isysquery/d2ff8917-d81d-4e51-9790-e0e3f9f67593/12/doc/>



Getting on an Upward Spiral

In Action to Improve Healthcare Quality